



RDBT5R3-FP143-333NC-RSC

1550/1310nm SC BOSA Module

1. Description

RDBT5R3-FP143-333NC-RSC Bi-Directional product is designed for P2P digital communication applications. It contains a 1550nm InGaAsP/InP MQW-FP laser diode, a 1310nm InGaAs photodetector, an edge filter(1550nm transmit/1310nm reflect) to separate 1550nm output light and 1310nm input light, coupling using single fiber with SC receptacle. The FP laser diode has included monitoring PD and ball lens cap. The product is designed for 155Mbps transmission in optical communication systems.

2. Features

- 2.1 Bi-Direction package with single fiber and SC/PC connector
- 2.2 1550nm FP laser diode as transmitter up to 155Mbps data rate
- 2.3 1310nm InGaAs PIN+TIA as receiver up to 155Mbps data rate
- 2.4 High Isolation, Return Loss and excellent Responsivity
- 2.5 Commercial-grade applications
- 2.6 Excellent performance and reliability

3. Applications

- 3.1 SONET/SDH transmission systems
- 3.2 P2P transmission systems

4. Absolute Maximum Ratings

Parameter	Symbol	Min.	Max.	Unit	Comments
Operating Temperature	T_{op}	0	70	°C	
Storage Temperature	T_{stg}	-40	85	°C	
Storage and Operating Humidity	-	5	85	%	
LD Forward Current(Transmitter)	I_{LD}	-	120	mA	
LD Reverse Voltage (Transmitter)	V_{RL}	-	2	V	
PD Forward Current(Transmitter)	I_{FD}	-	2	mA	
PD Reverse Voltage(Transmitter)	V_{RD}	-	15	V	
Power Supply Voltage(Receiver)	V_{CC}	-	+4	V	
Lead Soldering Temperature/Time	T_{slid}/t	-	260/10	°C/s	Temperature/Time



5. Optical and Electrical Characteristics($T_c=25 \pm 3 \text{ }^\circ\text{C}$, unless otherwise specified)

Transmitter						
Parameter	Symbol	Min.	Typ.	Max.	Unit	Condition
Output Power	Pf	0.3	-	0.8	mW	CW, Iop=Ith+20mA
Threshold Current	I _{th}	-	7	15	mA	CW
Forward Voltage	V _f	-	-	1.5	V	CW, Iop=Ith+20mA
Center Wavelength	λ_c	1480	1550	1580	nm	CW, Iop=Ith+20mA
Spectrum Width	$\Delta \lambda$	-	-	3.0	nm	CW, Iop=Ith+20mA
Tracking Error (Note 1)	TE	-1.0	-	1.0	dB	T _c =0~70 °C
Monitor Current	I _m	100	-	1000	uA	CW, Iop=Ith+20mA, V _R =1V
Monitor Dark Current	I _D	-	-	0.2	uA	V _R =10V
Data Rate	Br	155	-	-	Mbps	CW, Iop=Ith+20mA, $\lambda=1550\text{nm}$
Note1: I _m hold(@Ith+20mA, 25 °C), TE = 10log(P _{Tc} / P ₂₅), T _c =0~70 °C, APC						
Receiver						
Parameter	Symbol	Min.	Typ.	Max.	Unit	Condition
Operating Wavelength	λ_{op}	1260	1310	1360	nm	CW
Supply Voltage	V _{cc}	3.0	3.3	3.6	V	
Supply Current	I _{cc}	-	28	35	mA	
Resposivity	R	0.8	-	-	A/W	Pin=-30dBm, $\lambda=1310\text{nm}$
Optical Sensitivity	Sen	-	-36	-34	dBm	AC, RL=50Ω,NRZ 1.25Gbps, PRBR=2 ²³ -1
Saturation Power	P _s	-3	0	-	dBm	BER=10 ⁻¹⁰ , $\lambda=1310\text{nm}$
-3dB Bandwidth	BW	70	-	-	MHz	AC, RL=50Ω, Pin=-20dBm, $\lambda=1310\text{nm}$
Dark Current	I _d	-	-	5	nA	
Output Impedance	R _o	-	50	-	Ω	
Data Rate	Br	155	-	-	Mbps	CW, $\lambda=1310\text{nm}$



6. Package Information & Pin Definitions

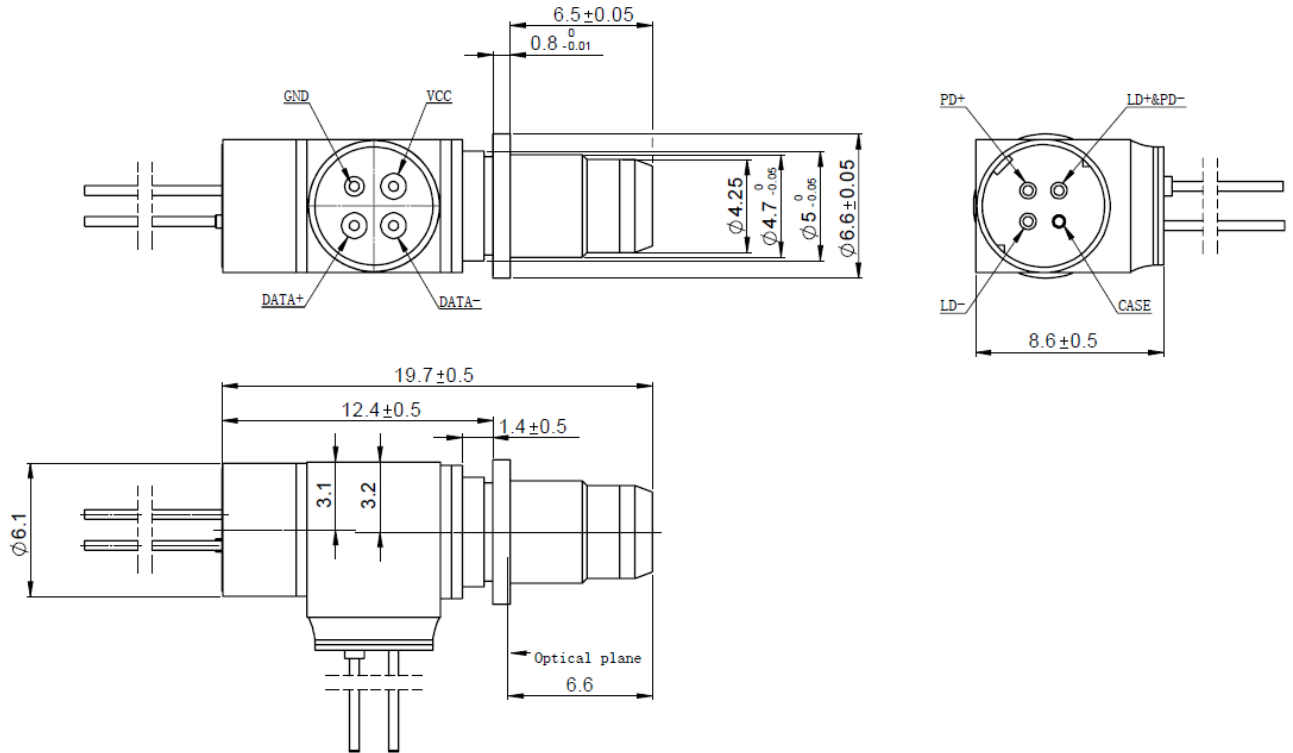



7. Ordering Information

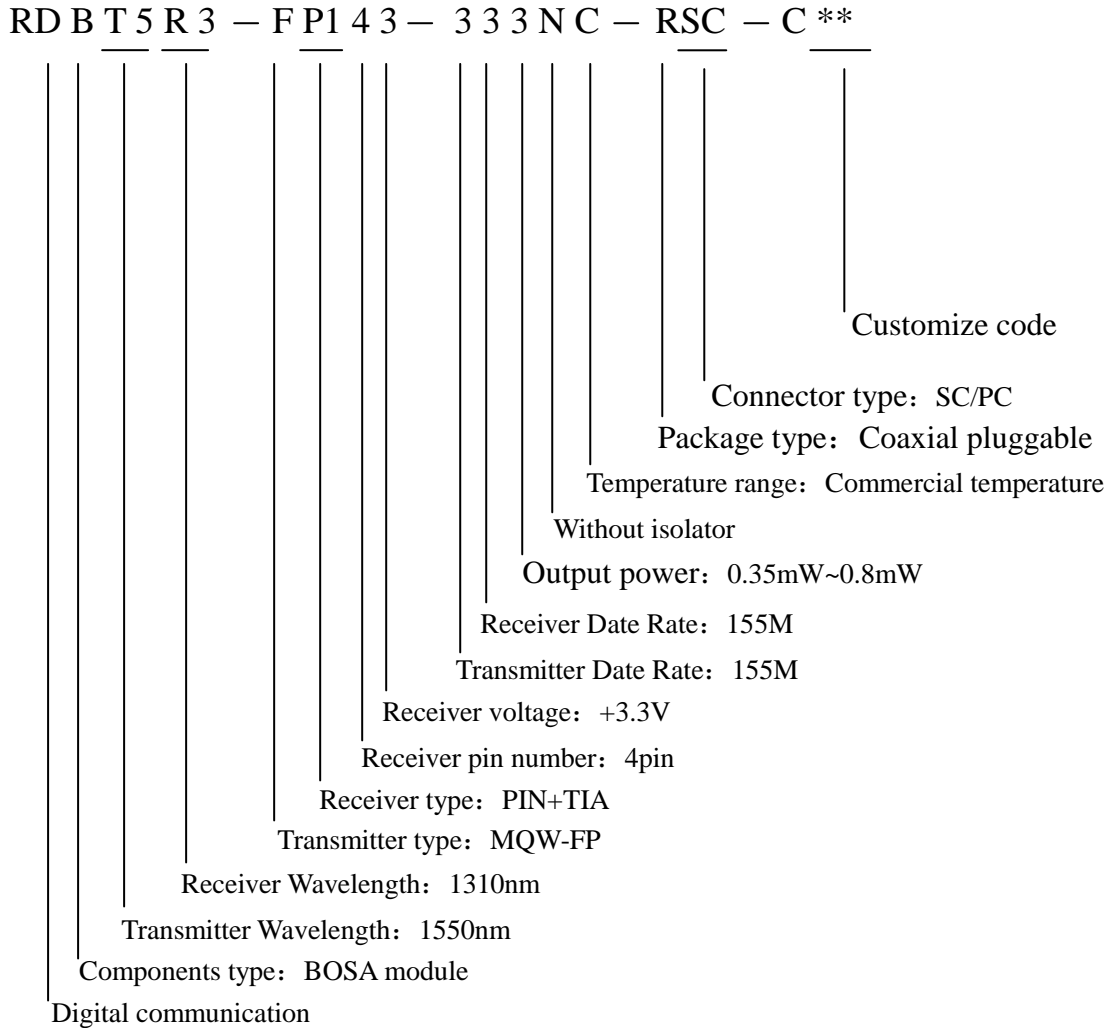

8. Warning

- 8.1 Radiation emitted by laser devices can be dangerous to the eyes. Avoid eye or skin exposure to direct or scattered radiation.
- 8.2 Handled in the same manner as ordinary semiconductor devices to prevent the electro-static damages. For safekeeping and carrying, the modules should be packaged with ESD proof material. To assemble the modules on PCB, the workbench, the soldering iron and the human body should be grounded.
- 8.3 Pay special attention to the atmosphere condition because the dew on the module may cause some electronic damages.
- 8.4 Under such a strong vibration environment as in automobile, the performance and reliability are not guaranteed.